

# Introduction to Steel Doors and Frames

Courtesy of the Steel Door Institute



**Standards As Tough As Steel.™**

## **Table of Contents**

Steel Doors and Frames 101 – Page 3

Steel 101 Quiz – Page 12

Fire Door Assemblies – Page 13

Fire Quiz – Page 20

Specialty Steel Doors – Page 21

Specialty Steel Quiz – Page 31

Quiz Answers – Page 32



# Steel Doors and Frames 101

## Introduction

Steel is very strong, and in its unaltered state, can withstand significant natural and man-made abuse. Properly installed and maintained hollow metal doors often last 30 years or longer. When repairs are necessary, they typically occur in the field at relatively low cost. Steel doors have a low total cost of ownership compared to other door materials.

You may hear these doors and frames referred to as “steel” or “hollow metal”. Generally, architects refer to them as “steel” and distributors and manufacturers say “hollow metal”. Please note that they are referencing the same product and the terminology may be used interchangeably.

## Anatomy of a Door Opening

### Head (header)

The horizontal member which forms the top of a frame

### Hinge jamb

The vertical frame member prepared for hinges or pivots

### Strike jamb

The vertical frame member prepared for a strike

### Light

A glazed opening

### Door face

The exposed surface of the door not including the vertical edges and top and bottom

### Lock set

The hardware and components that make up the locking or latching mechanism on a door

### Strike plate

A metal plate affixed to a doorjamb with a hole or holes for the bolt of the door. When the door is closed, the bolt extends into the hole in the strike plate and holds the door closed.

### Core

The material(s) in a hollow metal door or panel

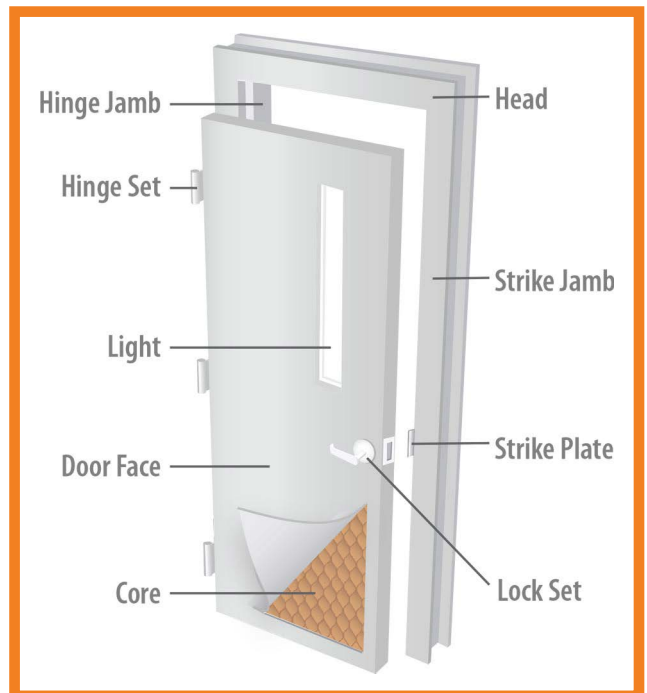

## Fire Rated Doors and Frames

Fire rated doors and frames play a vital role in keeping people safe and minimizing property damage during a fire. In fact, there has never been a loss of life from a fire in a building with properly installed and maintained fire doors.

Fire doors must meet the requirements of the International Building Code and International Fire Code, as well as NFPA 80 Standard for Fire Doors and Other Opening Protectives. Fire ratings range from 20 minutes to 3 hours. Hollow metal is the only door material widely available with a 3 hour label.

If the wall is fire rated, the frame and door must be fire rated as well. In the event of a fire, **temperature rise doors** minimize the heat transfer to the non-fire side of the door so people can safely escape from a burning building. These doors are built with a specifically designed core and are commonly found in the stairwells of high rise buildings.



## Americans with Disabilities Act (ADA)

The Americans with Disabilities Act (ADA) ensures building access to people with disabilities, of which doors play an important role. ADA requirements for doors in “places of public accommodation” touch on a variety of characteristics, including:

**Minimum Height**

**Opening Force**

**Closing Speed**

**Hardware**

**Glasslight Location**

**Minimum Door Width**

**Minimum Maneuvering Clearances**

**Threshold**



## Types of Frames

Frame profiles are generally either masonry/flush frames or slip-on drywall frames. The two most common types of frames and elevations are knock down (KD) and welded. **KD frames** come in pieces. The frame is then assembled and installed into an opening. **Welded frames** are manufactured and delivered in one piece. They are set in place and then the masonry is built around the welded frames.

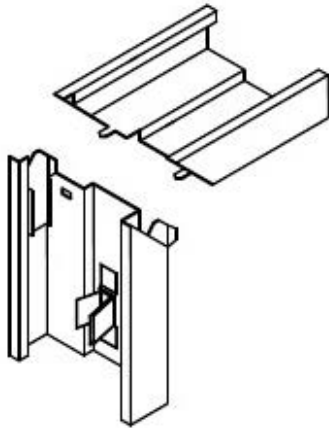

### KD Drywall Frames

Also called KD pressure-fit or slip-on drywall frames, these frames are specified for installation in existing drywall openings. They are shipped disassembled, use compression anchors, and have interlocking tabs and slots in the corners.

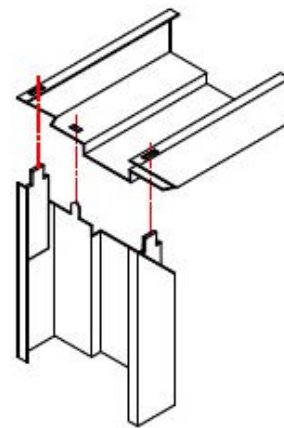

### Standard KD Frames

Standard KD frames are specified for new wall construction. They generally have slots and tabs, but use standard anchors instead of compression anchors.

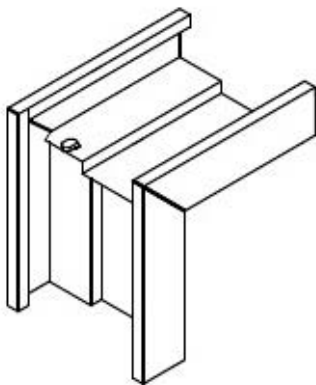

### Face Welded Frames

The most common type of welded frame. The joints between the head and jamb faces have a continuous weld on the visible side of both faces only. Frames are shipped assembled.

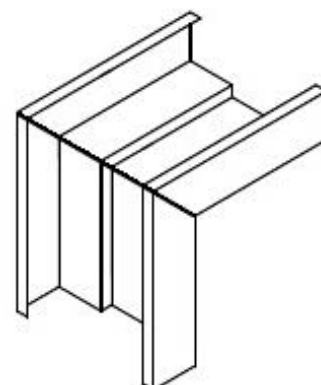

### Continuously Welded Frames

Also called full profile welded or fully welded. The corner/perimeter joints have all elements of the frame member continuously welded including soffits, stops, rabbet, faces, and returns.

## Frame Profile

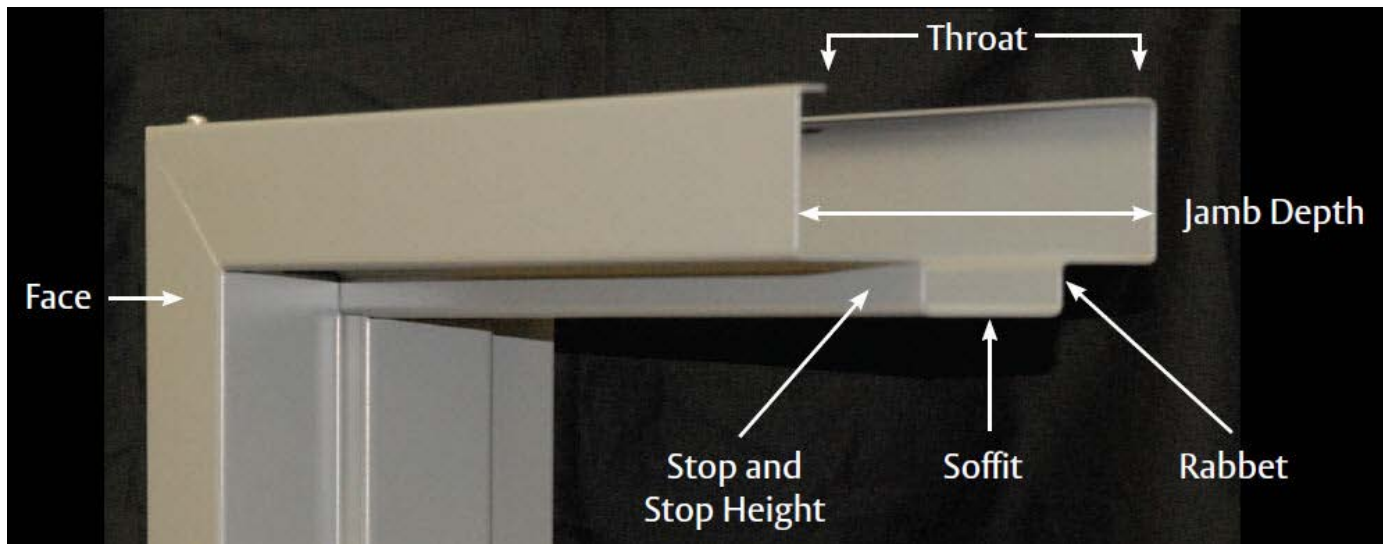

### Face

Exposed part of the frame

### Throat

Opening between the backbends of the frame

### Jamb depth

Overall width of frame profile—face to face dimension

### Stop

Part of frame door the closes against

### Rabbet

The area on either side of the soffit, available in a single or double rabbet design

### Soffit

The area between the rabbets

## The Frame Opening

### Nominal opening

The distance measured between the frame. The **net opening** is the measurement of the door slab.

### Undercut

Clearance between the bottom of the frame and the door

### Door width and door height

Measurements of the width and height inside of the frame, less the clearance

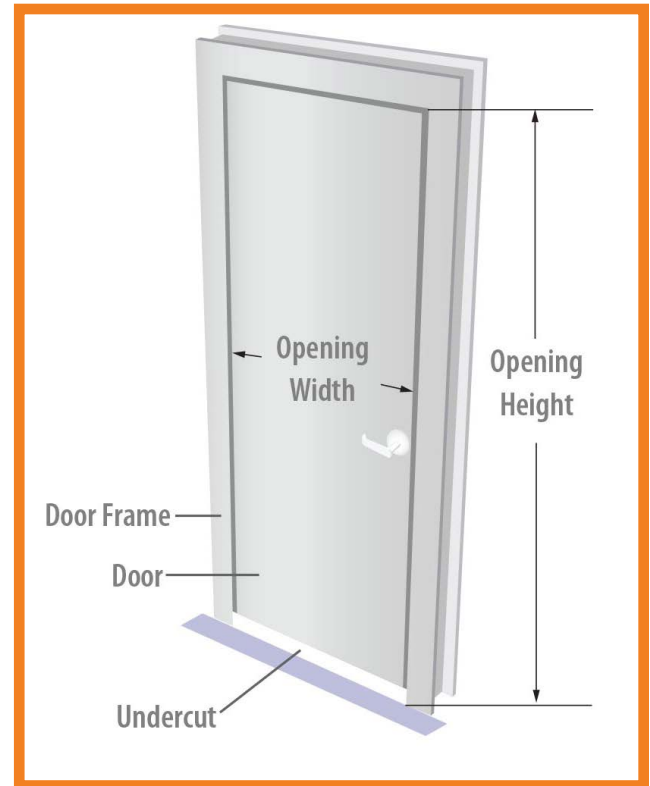

## Anchoring

Anchors are used to affix the frame to the wall. The type of anchor depends on the wall, generally either stud or masonry.

There are a variety of **stud wall anchors** that are specific to each wall type. They are often shipped loose with the frames or can be welded into the jambs. **Masonry wire anchors** are installed in masonry frames as the wall is built and can be resized to match the jamb depth of the frame as needed.

**Note - Altering anchoring methods may negate the fire rating of the opening.**



## Elevations

There are endless frame possibilities.

**Sidelights** are physically connected to the side of the door. **Transoms** are an overhead light or panel. Many frames have more than one type of elevation. This school entrance has sidelights and transoms, plus the doors have vision panels.



## Performance Levels of Doors

Architects will stipulate the performance level in their specifications. *ANSI/SDI A250.8 - Specifications for Standard Steel Doors and Frames* assigns door performance levels from 1-4. The gauge of steel is thicker with each level, and the heavier duty the door, the more it costs and weighs.

Level	Thickness		Manufacturers Standard Gauge
	Inches	mm	
1 - Standard Duty	0.042	1.0	18
2 - Heavy Duty	0.053	1.3	16
3 - Extra Heavy Duty	0.053	1.3	16
4 - Maximum Duty	0.067	1.7	14

Level one doors are **standard duty** and are designed for applications with minimal wear and tear, such as an interior office door.

Level four doors are **maximum duty** and are built for abusive environments or where security is imperative.

## Door Selection

There is a [Door Selector Tool](#) on the SDI website that recommends door performance levels based on the location of the opening (ie. school gymnasium, office stairwell, etc.). Just visit [steeldoor.org](http://steeldoor.org) and click “Door Selector” in the main menu.

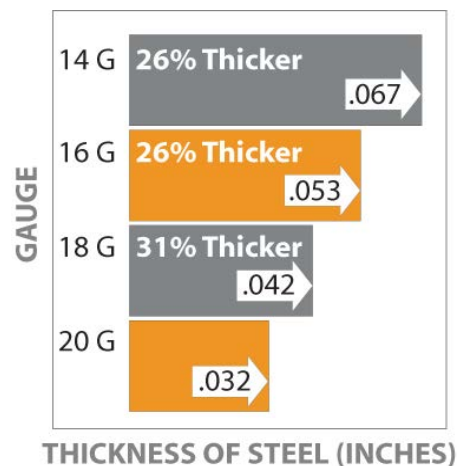



## Door Cores

Hollow metal door manufacturers use a variety of core materials to meet the desired performance levels.

### Honeycomb

Moderate sound reduction, minimal insulation

### Polystyrene

Moderate insulation, minimal sound reduction

### Polyurethane

High insulation, minimal sound reduction

### Mineral

Used for temperature rise doors, which reduce the heating of the “cool” side of the door

### Steel Stiffened with Fiberglass Insulation

Withstands abuse and high usage; good sound resistance

These are the most common core materials, however hollow metal door manufacturers have proprietary cores as well, particularly for high performance products.

Honeycomb core



## Galvannealed vs. Galvanized Steel

Hollow metal doors and frames are generally made with galvannealed steel, not galvanized steel.

**Galvanized steel** has that spangled look and is often found in coating weights of G40, G60, and we’ve seen specs with up to G90. The issue with these “G” coatings is that primer doesn’t stick very well to them so it hinders the protection of the steel doors. Although sometimes specified and manufactured, the Steel Door Institute does not recommend the G Type zinc coating for doors and frames.

**Galvannealed steel** is still zinc coated – without the spangled look – and is generally coated at A40 or A60. A40 is the minimum recommended weight, while A60 offers better corrosion protection. It is not recommended to go higher than A60 because it reduces paint adhesion. Galvannealed steel is also known as “paintlok” for its excellent paint adhesion, which is why it is by far the most common type of steel used in hollow metal doors and frames.

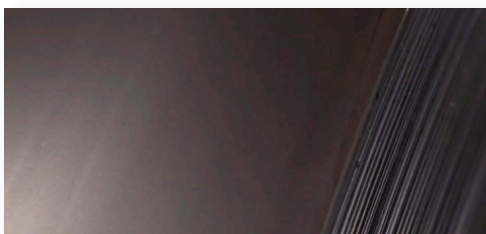

Galvannealed steel



Galvanized steel

## Hardware Reinforcement

You've probably experienced the frustration of a door that doesn't operate properly. Maybe it was sagging, or perhaps the hardware was loose and falling off. While the initial reaction may be to blame the quality of the door or hardware, the majority of these issues are due to poor installation. Despite the manufacturers not being at fault for improper field installation, their reputations are still on the line.

The Steel Door Institute created *ANSI/SDI A250.6 Recommended Practice for Hardware Reinforcing on Standard Steel Doors and Frames* as a guide to door reinforcement and the installation of door hardware. It should be referenced by hollow metal door installers.

The correct hardware must be selected to ensure the door and frame are properly reinforced. Screws must have **three threads** within the door to effectively secure the hardware.

A level two 18 gauge door is only thick enough for **two threads**, therefore the door must be reinforced per ANSI/SDI A250.6.

## The Risks of Grouting Frames

There are more risks than rewards when grouting frames. Some specifiers or contractors prefer grouted frames because they incorrectly believe it improves the structural integrity. While grout can improve the sound deadening qualities of a frame, a properly anchored frame will not be any sturdier if it is grouted.

Grouting should never be specified for drywall construction. When the grout is drying, the moisture can either go into the drywall (weakening it) or into the frame or hardware (causing rust).

Grouting is generally unnecessary for masonry construction as well. To be clear, if the grouting is done properly it will not cause any issues with the frame. Unfortunately, thin pumpable slurry is often used and its excess water causes rust. If grouting is requested, it should always be hand troweled and never pumped.

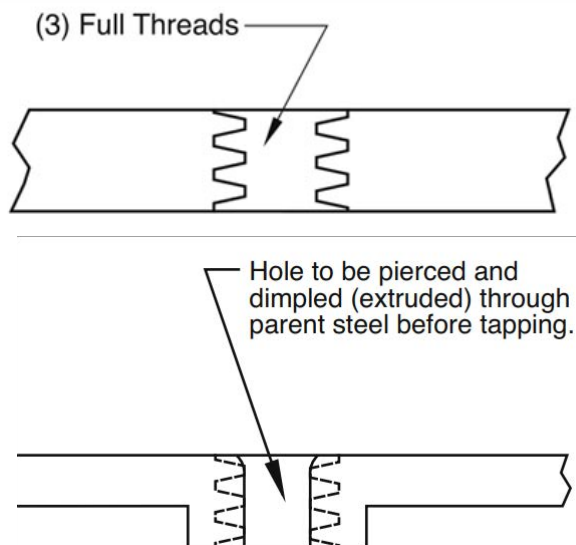

# Appearance

Steel doors are available in a variety of finishes and constructions. Some manufacturers offer to finish paint them for the customer. They are also available in stainless steel for a modern look, with a faux wood grain finish, or embossed where a decorative opening is desired. Embossed doors can range from a single panel (see image) up to eight or more panels. These doors can achieve a three hour fire rating, just like other steel doors.



# Steel is Green

Steel is the most recycled material in North America. It is an infinitely recyclable material due to its inherent durability. Most other materials degrade in the recycling process and must be discarded after only being recycled once or twice.

Steel is North America's #1 Recycled Material*	
Materials	Tons
Steel	2,740,567
Paper	1,859,541
Aluminum	166,094
Glass	113,016
Plastic	85,213

\*Data from 2015

The “green” nature of steel allows it to contribute LEED points. In 2018, the Steel Door Institute completed the first industry-wide, LEED-compliant Environmental Product Declarations (EPDs) for steel doors. This was achieved by undergoing a “cradle-to-gate” assessment for two products: (1) **heavy duty flush panel steel doors made with a polystyrene core** and (2) **5-3/4” 16-gauge steel prime painted door frames**. All Steel Door Institute member manufacturers offer these products, which can contribute toward the LEED v4 Materials and Resources category, “Building Product Disclosures and Optimization”.

## Steel Doors and Frames 101 Quiz

1. The distance measured between the frame is the \_\_\_\_\_ opening.
  - a. Net
  - b. Gross
  - c. Nominal
  - d. Practical
2. What is the highest commonly available fire rating for a door?
  - a. 20 minutes
  - b. 45 minutes
  - c. 1 hour
  - d. 3 hours
3. Which type of door retards the transmission of heat through the door?
  - a. Temperature drop doors
  - b. Temperature rise doors
  - c. Double insulated doors
  - d. None of the above
4. Masonry frames are installed after the wall is built.
  - a. True
  - b. False
5. Architects should stipulate the doors' performance level in their specs. ANSI/SDI A250.8 states that Level 1 is standard duty. Which level is for maximum duty?
  - a. 2
  - b. 3
  - c. 4
  - d. 5
6. Which gauge of steel is thicker?
  - a. 20 gauge
  - b. 14 gauge
7. Steel doors are generally prime painted with a rust-inhibiting primer.
  - a. True
  - b. False
8. Which type of steel is preferred for steel doors and frames due to better paint adhesion?
  - a. Galvanized
  - b. Galvannealed

Quiz answers are on page 32.



# Fire Rated Door Assemblies

There's a lot to learn when it comes to fire rated products. This section of Introduction to Steel Doors and Frames covers the fundamentals.

Fire rated doors and frames play a vital role in keeping people safe and minimizing property damage. They are proven to prevent fire from spreading from one area to another, which also allows the occupants to safely evacuate. Here is just one example of how fire doors can save lives.

Here's an example of how a closed fire door protected the Robert Moses Nature Center from a fire that started in the workshop.



Photos courtesy of  
Fire Protection Specialist Christopher Taylor  
NYS Office of Fire Prevention and Control



Properly Closed  
Fire Door  
Prevented Fire  
Damage To This  
Entire Section of  
The Building

# Fire Rated Door Assemblies

Fire doors must be closed and latched to provide protection. During a fire, smoke would enter the stairwell through this open door and hinder the occupant's ability to evacuate. The barrel is also partially blocking the stairwell walkway and could be an obstacle during a mass evacuation.

An active latchbolt is required for each fire door to keep the door latched during a fire.



## Common Locations

Building code specifies where fire door assemblies are required. Most US states use the International Building Code (IBC), many include state modifications.

### Stairwells

Doors in stairwells are typically fire door assemblies because they protect the stair enclosure as a means of egress. 450-degree temperature rise fire doors reduce the transfer of heat from one side of the door to the other and may be required for some stairwells, typically in non-sprinklered buildings.

### Residential Corridors

Dwelling units in a residential occupancy such as an apartment building, hotel, or dormitory usually have fire-rated entry doors to help prevent fire from spreading beyond the unit where it began. They also protect the corridor as a means of egress.

### Incidental Use Areas

Rooms with a higher risk of fire are sometimes required to have fire-resistance-rated walls and fire door assemblies. Incidental use areas may include certain electrical rooms, furnace rooms, boiler rooms, refrigerant machinery rooms, incinerator rooms, paint shops, laboratories, and large laundry rooms. The building code specifies which types of rooms require fire door assemblies.



# Classification of Openings

**Class A** – Openings in **fire walls** and in walls that divide a single building into fire areas

**Class B** – Openings in **enclosures of vertical communications** through buildings and in 2-hour rated partitions providing **horizontal fire separations**

**Class C** – Openings in walls or partitions **between rooms and corridors** having a fire resistance rating of 1 hour or less

**Class D** – Openings in **exterior walls** subject to **severe fire exposure** from outside the building

**Class E** – Openings in exterior walls subject to moderate or light fire exposure from **outside the building**



- Fire door assemblies are also classified by the number of minutes they have been tested to withstand fire:
- 20 minutes
  - 45 minutes
  - 60 minutes
  - 90 minutes
  - 3 hours

## SDI 118

SDI 118 *Basic Fire Door, Fire Door Frame, Transom/Sidelight Frame, and Window Frame Requirements*, a publication of the Steel Door Institute, covers basic fire door assembly requirements. It includes a graphical representation of the NFPA 80 opening protective requirements.

The fuel load adjacent to a door is typically lower than the fuel load against a wall, so the rating of a fire door assembly is usually lower than the rating of the wall. Fire doors that are no longer used should be replaced with a construction equivalent to the wall rating.

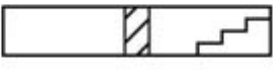
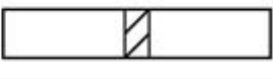
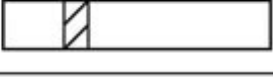
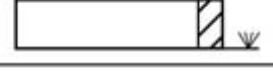
**Table 1 – Fire door openings**

Opening	Wall Rating	Door and Frame Rating	Description and Use
	4 Hour	3 Hour (180 minutes)	These openings are in walls that separate buildings or divide a single building into designated fire areas.
	2 Hour	1-½ Hour (90 minute)	Openings of this type are used in enclosures of vertical communication or egress through buildings. Examples of these types of openings include stairwells and elevator shafts.
	1 Hour	1 Hour (60 minute)	These door and frame assemblies divide occupancies in a building.
	1 Hour	¾ Hour (45 minute)	For use where there are openings in corridors or room partitions.
	2 Hour	1-½ Hour (90 minute)	This opening is in a wall where there is the potential for severe fire exposure from the exterior of the building.
	1 Hour	¾ Hour (45 minute)	This opening is in an exterior wall that has the potential to be exposed to moderate to light fire from the exterior of the building.
	1 Hour	½ Hour (20 minute)	These openings are in corridors where smoke and draft control is required. The minimum wall rating is ½ hour.



## Labels

Door components used as part of a fire door assembly must be listed for that purpose. It is okay to have components from different manufacturers and listing laboratories in the same fire rated assembly. For example, having a door from one manufacturer and hardware from another.

Fire labels must remain visible and legible. They include detailed information such as the rating, test methods, required latch throw, smoke resistance, and an issue number. The issue number can be used for further information.

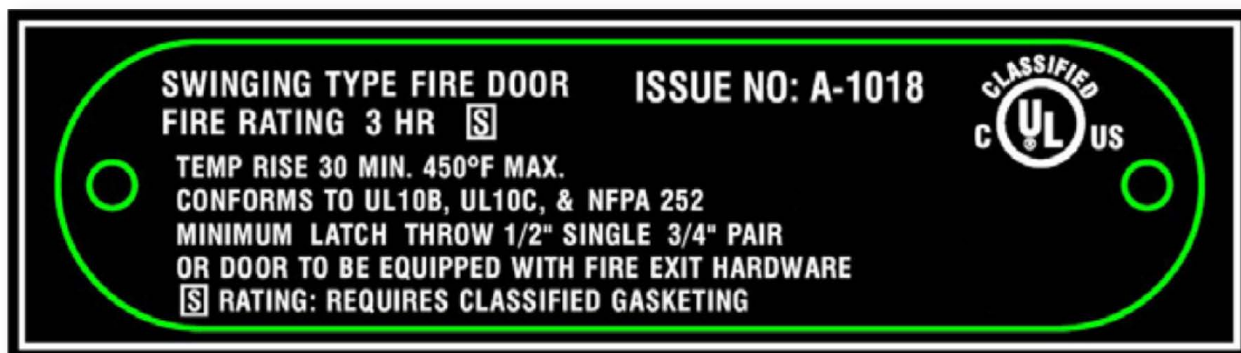

## Testing

Manufacturers must have their products undergo fire testing to have their products labeled. The testing is conducted in a certified laboratory with a test furnace to replicate the effects of a fire. The positive pressure test method requires a neutral pressure plane at 40 inches above the floor after 5 minutes. This test method more accurately replicates an actual fire than previous methods.

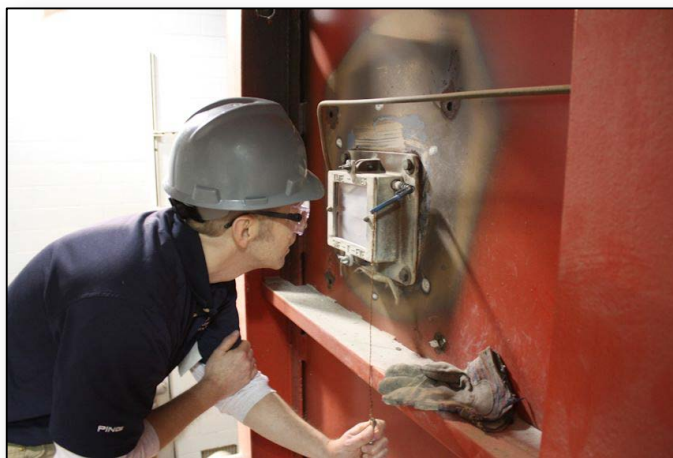

### Hose Stream Test

A hose stream test is conducted after the fire test, however it is typically not required for 20-minute doors in the US.





## Design Considerations

Manufacturers face limitations on the fire rated doors and frames they can produce.

- Fire-resistance-rated frames must have **fire-resistance-rated glazing**. There are different limitations depending on the type of glazing.
- **Door opening sizes** are also limited by the manufacturer's listings, not to mention the structural integrity and ability to function properly.
- **Jamb depth** of frame relates to wall thickness. It's important to verify the availability of a fire rated configuration for custom profiles.
- Caution must be taken with **light and lock cutouts** to ensure they do not negate the fire rating.



## Operation of Doors

Fire doors generally must be either self-closing, automatic-closing, or power-operated.

- **Self-closing doors** – closer or other device that closes the door each time it is opened.
- **Automatic-closing doors** – an electronic hold-open mechanism that releases and allows the door to close during a fire. The IBC requires hold-opens used in most fire door locations to be smoke-activated, not heat-activated.
- **Power-operated doors** – automatic operators must be disconnected during a fire.

## Clearance and Undercuts

The clearances of fire rated doors are limited by NFPA 80. The clearance at the **bottom** of the door may exceed 3/4". The **head, jambs, and meeting stiles** of a hollow metal door must be 1/8" +/- 1/16".

Doors with non-compliant clearances cannot be remedied by adding *standard* gasketing products. The product must be *specifically listed* for use on a door with oversized clearances.

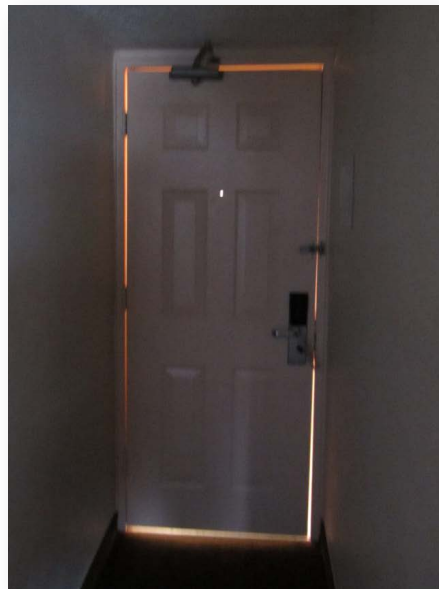

## Protection Plates

NFPA 80 limits the height of protection plates on fire doors. They may be field-installed within the bottom 16" of the door without a label required on the plate. Field-installed plates mounted above the bottom 16" of the door must be labeled. Protection plates may also be installed under label service (at the factory or in an approved shop) as allowed by the manufacturer's listings.



## Plant-ons

Plant-ons are decorative trim applied to the face of a door. They may negate the fire rating of a door, and therefore the manufacturer's listing requirements must be referenced prior to installation.



## Glazing

NFPA 80 restricts the size and type of glazing allowed, which is limited to the maximum area tested by the door or frame manufacturer and the glazing manufacturer. Each piece of glazing must have a label or etching.

IBC requires glazing in doors, sidelights, and other hazardous areas to be impact-resistant. More than 2,000 accidents from non-impact-resistant traditional wired glass are reported in schools each year. Each piece of impact-resistant wired glass must be marked to indicate compliance.

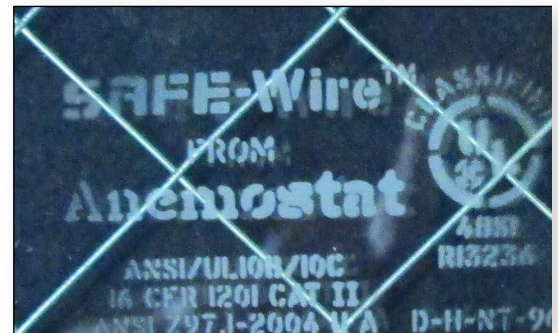

## Signage

Signage on fire rated doors must not:

- Exceed 5% of the door face
- Impair door operation
- Be placed on glazing
- Be affixed with mechanical attachments such as screws or nails

Why is the fire door sign on the door to the right non-compliant?



## Fire Door Assembly Inspection

Maintaining compliance with fire door assemblies is the responsibility of the building owner or property manager. The 2013 edition of NFPA 80 requires fire doors to be inspected by a Qualified Person **after installation, after maintenance work, and annually**. They will verify that the:

- Label is visible and legible
- Glazing, vision kits, and glazing beads are securely fastened
- Door, frame, hinges, hardware, and threshold are secure, aligned, and in working order without damage
- Clearances are within acceptable limits
- Assembly does not have field modifications outside of what is allowed by NFPA 80
- Signage meets requirements of NFPA 80

Deficiencies noted must be repaired “without delay”.

## Fire Rated Door Assemblies Quiz

1. Where is a common location for fire doors?
  - a. Stairwells
  - b. Residential corridors
  - c. Incidental use areas
  - d. All of the above
  
2. What is NFPA 80?
  - a. The rating that shows how long a door will perform in a fire before failing.
  - b. The rating that shows the maximum temperature a door can withstand before failing.
  - c. A standard for fire doors and other opening protectives
  - d. None of the above
  
3. The rating of a fire door assembly is usually lower than the rating of the wall.
  - a. True
  - b. False
  
4. Which is true regarding fire door labels?
  - a. They must remain visible and legible
  - b. They include detailed information such as the rating, test methods, required latch throw, smoke resistance, and an issue number
  - c. They are applied on the door by the building owner
  - d. Both a & b
  
5. Which test more accurately replicates an actual fire than previous test methods?
  - a. Positive pressure testing
  - b. Negative pressure testing
  - c. The hose stream test
  - d. The 60 minute test
  
6. Fire-resistance-rated frames do not require fire-resistance-rated glazing.
  - a. True
  - b. False
  
7. IBC prohibits the use of louvers in smoke barriers, smoke partitions, or corridor smoke and draft control assemblies.
  - a. True
  - b. False

Quiz answers are on page 32.



# Specialty Steel Doors

Steel doors and frames are often ordered as a standard product. However, design professionals are increasingly putting a new twist on an old classic by modifying them for better aesthetics or performance. This section covers the most common specialty steel doors and frames, including:

- Acoustic
- Blast Resistant
- Bullet Resistant
- Tornado Resistant
- Hurricane Resistant
- Stainless Steel
- Lead-Lined
- Custom

## Acoustical Door Assemblies

In the age of open floor plans and chiming cell phones, silence is golden. That may explain the growing demand by architects and building owners for sound resistant doors.

Acoustic doors are engineered to prevent a specific amount of sound from passing through a door. They have been used in loud environments such as manufacturing facilities and music studios for decades, but are becoming increasingly popular in office buildings, hotels, and schools too.

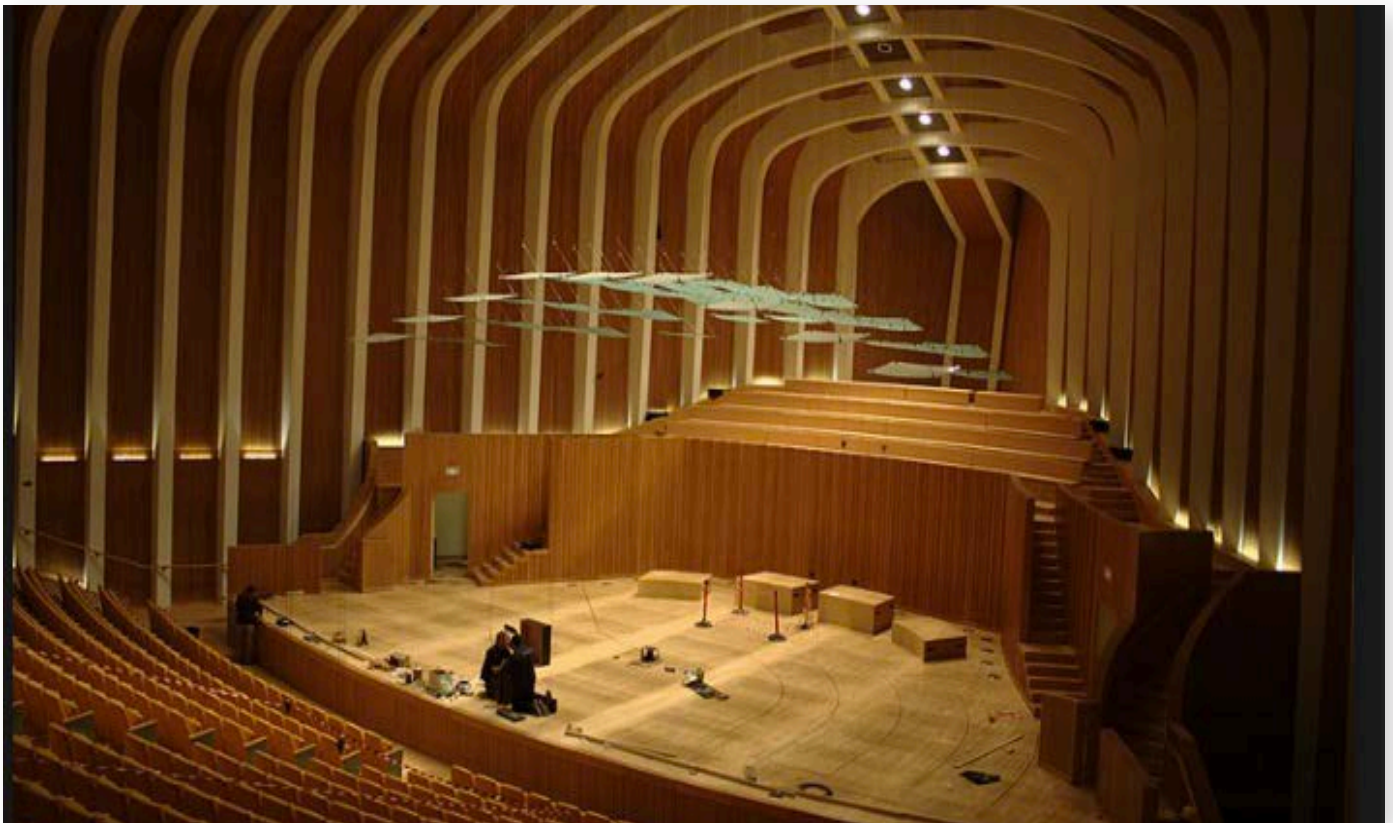

## Sound Transmission Control

A door's Sound Transmission Control (STC) rating specifies how much sound is prevented from passing through the door. The higher the STC rating, the more sound resistant the door. The STC scale is a logarithmic progression: an increase of three points doubles the sound transmission reduction.

STC	What can be heard
25	Normal speech can be understood easily and distinctly through wall
30	Loud speech can be understood fairly well, normal speech heard but not understood
35	Loud speech audible but not intelligible
40	Onset of "privacy"
42	Loud speech audible as a murmur
45	Loud speech not audible; 90% of statistical population not annoyed
50	Very loud sounds such as musical instruments or a stereo can be faintly heard; 99% of population not annoyed.
60+	Superior soundproofing; most sounds inaudible

Single door openings are available over STC 50 even with a standard 1 ¾" thickness. Pairs of doors are generally available up to STC 40-48. The STC rating of **standard** hollow metal doors is often in the 20-30 range. Doors above STC 40 may be needed in locations where sound control is critical, such as an office where confidential meetings are held.

For doors with glass kits, the STC rating decreases as the glass kit size increases. The use of laminated glass with an air pocket is recommended to help reduce the transmission of sound waves.

## Outdoor-Indoor Transmission Class (OITC)

OITC measures the sound transmission from the external environment into the building envelope. It includes a range of frequencies lower than the STC testing to more closely replicate the sounds of rail and vehicular traffic.



## Test Methods

Acoustic door assemblies are tested in accordance with ASTM E90 acoustical ratings. A door is installed into a test wall with a high STC rating (greater than 60) between two rooms. One room is the source of the sound, while the other is the receiving room where the measurement will take place. Different sound frequencies are generated and a sound attenuation value is determined at each frequency.

For an **inoperable test**, the perimeter of the door opening is sealed with putty and tape. The resulting acoustical value is solely for the door and frame assembly. While this is a valid test condition, it is not indicative of the STC performance of an operable door.

In the **operable test**, the door is in working condition and must open and close. The resulting acoustic rating also highlights the loss of STC between the two tests. The loss is typically 1 to 5 STC points depending on the quality of the seal and threshold assembly. Manufacturers publish the STC rating from the operable test.

## Blast Resistant Assemblies

Blast resistant assemblies protect people and property from explosions and shrapnel. The DOD, DOE, Department of Homeland Security, and petrochemical industry building standards are increasingly requiring blast resistant doors. The most common buildings for these blast doors include government buildings, refineries, and chemical storage, among others.

Steel blast resistant doors are available that can withstand peak blast pressures ranging from very low levels of less than 1 lb. per square inch (psi) to more than 50 psi, as well as long blast durations which increase the impulse loading.





## Blast Resistant Definitions

### Blast pressure

The maximum pressure expected to be exerted on the assembly by the projected blast event (measured in psi).

### Blast duration

Measured in milliseconds, the length of time required for the blast pressure to decay to zero.

### Blast impulse

The blast energy as described by the area under the pressure vs. time curve (measured in pressure-time units such as psi-msec).

### Blast direction

The direction of the blast load relative to the door assembly.

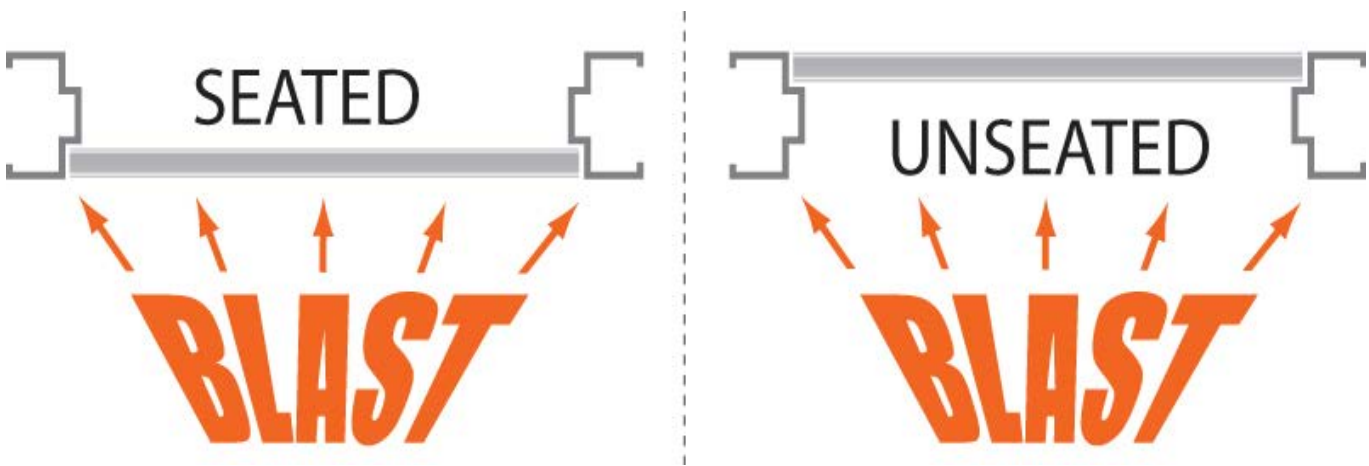

### Rebound

The percentage of the initial peak blast pressure that is reflected back on to the blast resistant unit.

### Required response

The acceptable level of damage that would result from the projected blast event on a door assembly. The responses range from Category I (no damage) to Category V (catastrophic failure). There are several different definitions of response provided in the following documents:

## Blast Door Standards

**ASTM F2247, ASTM F2927 and ASTM F1642** are commonly specified test methods for blast doors.

**UFC 4-010-01** is one of the primary specifications required for all Department of Defense related construction.

**ASCE** (Design of Blast Resistant Buildings in Petrochemical Facilities) and **PIP STC01018** are primarily used for petrochemical and offshore facilities.



When requesting a quote, manufacturers will need to be provided with:

- Door size
- Flush or with vision panel
- Peak pressure, impulse and standoff distance
- Seated or unseated
- Rebound requirements, if applicable
- Damage Category or Hazard Level (including the governing authority or specification such as ASTM F2247)

Generally, specifiers will be working with a blast consultant to determine the projected blast conditions and desired response category.

### Sample Blast Requirement

- Size: 3'0" x 7'0"
- Vision: Yes, 12" x 12" Visible
- Pressure: 4 psi
- Impulse: 28 psi-msec
- Blast Direction: Seated
- Rebound: 50%
- Damage Level Category: II per ASTM F2247

**Vision lights** require a check of the blast resistance of the entire assembly, including the vision kit and glazing. The mounting kit must be able to withstand the projected blast loading imparted by the glazing. In general, blast resistant glazing requires a laminated component comprising either the single glazing pane or the inside pane of an insulated glass unit.

### Blast Categories

- **Category I:** undamaged
- **Category II:** permanent plastic damage but operable
- **Category III:** non-catastrophic failure (inoperable but remains a barrier to blast)
- **Category IV:** limited hazard failure (may rebound open)
- **Category V:** high hazard failure (door may be a flying debris hazard)

## Bullet Resistant Assemblies

Bullet resistant doors are often used in government buildings, cashier stands, high crime rate areas or any structure where increased safety is desired. They are generally tested in accordance with UL 752 and assigned a level from 1-10 that defines how resistant the door is to gun fire.

Steel doors are typically available up to level 8. A security consultant should analyze the building conditions to determine the proper bullet resistance level required.

LEVEL	BULLET	CALIBER	SHOTS
1		9mm (124g) FMJ	3
2		.357 Magnum (158g) SP	3
3		.44 Magnum (244g) SP	3
4		.30 Caliber Rifle (180g) SP	1
5		7.62mm Rifle (150g) FMJ	1
6		9mm Multi (124g) FMJ	5
7		5.56mm Rifle (55g)	5
8		7.62 Multi Rifle (150g) FMJ	5
8 (AP)		30-06 Rifle (166g) AP	5

The doors may be flush or have full glass vision lights. They are also available in pairs.

Bullet resistant doors can be fire rated up to three hours and combined with STC and blast resistant capabilities.



## Specifying Bullet Resistant Doors

The standard that should be specified is often spelled out by whomever is commissioning the project.

- **UL 752** is the most common test method, which assigns a level from 1 – 10.
- **NIJ 0108.01** is one of the primary specifications used by the government.
- **NCEL-MIL-SAMIT** is generally used for military projects.

A variety of cores can be bullet resistant, such as steel stiffened, honeycomb, and polystyrene. Typically, bullet resistant doors should be ordered to a specific UL 752 level and not with specific core material. Many of the cores are proprietary at the higher performance levels.

## Tornado Resistant Assemblies

About one thousand tornadoes occur in the United States every year. Most of them wreak havoc in “Tornado Alley”, which runs from Texas to Alabama up to New York. However, tornadoes have occurred in every state.

Steel is the most prevalent door material to pass FEMA P-361 and ICC 500. No wood door, with or without metal sheathing, has successfully passed FEMA P-361. While tornado doors are similar in appearance to standard steel doors, they are highly engineered products and cannot be substituted by heavy gauge standard steel doors.

**FEMA P-361** offers best practices on the design and construction of safe rooms but FEMA does not regulate construction.

**ICC 500** is the Standard for the Design and Construction of Storm Shelters.

Tornado assembly components are approved and certified as an assembly and cannot be mixed and matched. These components include the **frame, door, hinges, anchors, and latching hardware**.

Proper installation of tornado doors is critical. An improper installation may result in the door sagging or not withstanding the labeled wind load. It is recommended to have a pre-installation meeting with the contractor, specifier, door supplier, and installer to discuss the installation.

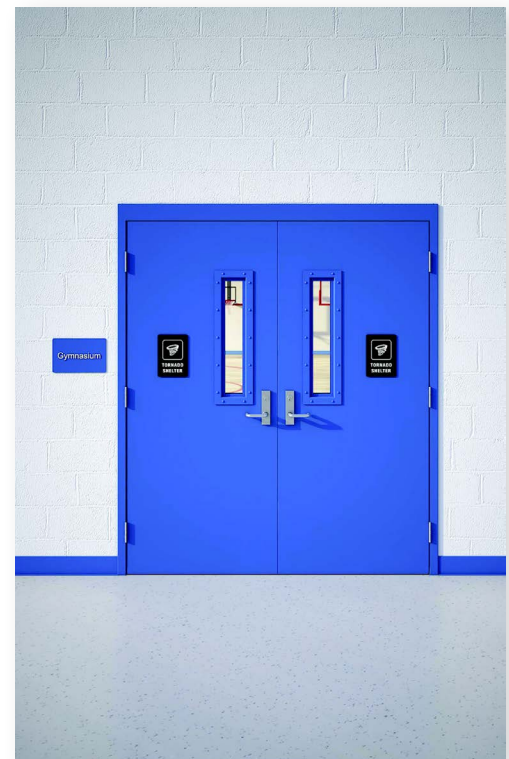

## Hurricane Resistant Assemblies

The United States averages 17 hurricanes per decade, 34% of which are classified as major (category 3, 4, or 5). In 1992, Hurricane Andrew killed 65 people and caused \$26 billion in damage—the impetus for city, county and state authorities to develop new hurricane-resistant building codes.

Hurricane doors dramatically reduce the chances of harm to people and property. They also allow for conformance to local or state code requirements. These specialty door assemblies are tested with the positive and negative pressures that occur in hurricanes. They are then rated with a “design pressure,” which is different than wind speed. For example, a wind speed of 170 mph produces a design pressure of +49/-53 psf.

When specifying hurricane doors, it’s important to:

- Ensure the structural engineer has provided a design pressure for each opening;
- Select listed opening assemblies with equal or greater design pressure values;
- Ensure the functional needs of the openings are met (i.e. rated with panic exit hardware, glazing, etc.).

**Steel hurricane-resistant assemblies can resist winds from 110 to 170 miles per hour. SDI member manufacturers produce these products in accordance with *ANSI/SDI A250.13 Testing and Rating of Severe Windstorm Resistant Components for Swinging Door Assemblies for Protection of Building Envelopes*, the Florida Building Code (FBC) and the South Florida Building Code (SFBC).**

There are three standard hurricane tests and associated test standards:

- **Large Missile Impacts** (TAS 201, ASTM E1886/E1996, ANSI A250.13, and ICC 500)
- **Uniform Static Air Pressure** (TAS 202, ASTM E330, and ANSI A250.13)
- **Cyclic Wind Pressure Loading Test** (TAS 203, ASTM E1886/E1996, and ANSI A250.13)



## Stainless Steel Doors

Stainless steel doors are generally requested for their sleek, modern appearance. They are also a good choice where rust and corrosion are a concern. For these reasons, they are found in a variety of buildings such as offices, hospitals, and food processing plants.

Stainless steel doors typically have a composite core—such as polystyrene or honeycomb—but may also be available with steel stiffeners. They can be fire and STC rated too. There are many finishing options, enabling architects to add a distinct design element to their doors. Standard industry finishes are referenced by #1-8. Lower number finishes are more matte, while higher numbers are more reflective. The most common finishes include:

- **#2B Unpolished** - suitable for painting, such as in concealed areas where stainless steel performance is required but aesthetics are not important;
- **#4 Brushed Satin** - low reflectivity;
- **#6 Long Grain Satin** - more reflective than a #4 finish;
- **#8 Mirror** - highly reflective; fine polishing lines are barely visible. Fingerprints show on mirror-like finishes, so they are best-suited for low traffic openings;
- ... and more such as angel hair, swirl and distressed.

The appearance of stainless steel finishes are not defined by standards, therefore it is common for customers to request a sample. Finishes are a design element to be specified and do not affect the performance of the door or frame. The specification should always be precise (“Finish #8”) and not descriptive (“brushed finish”).

Tip: Finishes with horizontal lines should be avoided because they are more likely to collect dirt than vertical patterns.

Due to alloy’s high oxidation resistance, stainless steel doors are common where rust or corrosion is a concern. These can be marine environments, areas with heavy rainfall or other locations with consistent moisture.

**Tip: Smoother finishes are better suited for corrosive environments.**

Stainless steel doors with a custom seamless edge wash easily and can be sanitized thoroughly, making them a popular choice for **sanitary environments** such as food handling facilities and medical buildings.





## Lead-Lined Doors and Frames

Lead-lined doors prevent the transmission of radiation. They are commonly specified for **x-ray protection** in clinics, hospitals, imaging centers, veterinary offices and other healthcare environments. They are also used for **radiation shielding** in buildings where security is a concern, such as aerospace, airports and defense environments.

Lead-lined doors are usually manufactured with a steel stiffened core, but other cores are sometimes used. These specialty doors are available:

- With vision lights
- With borrowed lights or sidelight frames
- Fire rated up to 90 minutes
- STC-rated
- Bullet resistant levels 1-4
- With stainless steel skins

The most common lead thicknesses in doors and frames are 1/16", 3/32", 1/8" and 1/4". Lead as thick as 1" is available for unique applications. The lead thickness value of the door and frame shall have the same or greater radiation attenuation value as the surrounding wall.

## Custom Steel Doors and Frames

Steel is incredibly versatile. Custom doors may be specified for **function**, perhaps with a non-standard width, height, or thickness. They are also used to bring a distinct **design element** to a building, often with a custom finish or unique shape.

Architects often request "**semi-custom products**", which are standard products ordered with unique attributes such as width, height, window location, or jamb profile.

"**Full custom products**" may be extremely oversized or have a special core because a standard core would be incompatible. Another custom request is for a special door thickness.

**Custom frames** may have arch tops and circular window frames for an eye-catching design. Non-right angle frames add a modern appearance and are found in museums, public architecture, universities, and churches.

Design professionals are encouraged to consult with the manufacturer or distributor early in the process. They've seen it all and can be very helpful in the design process.

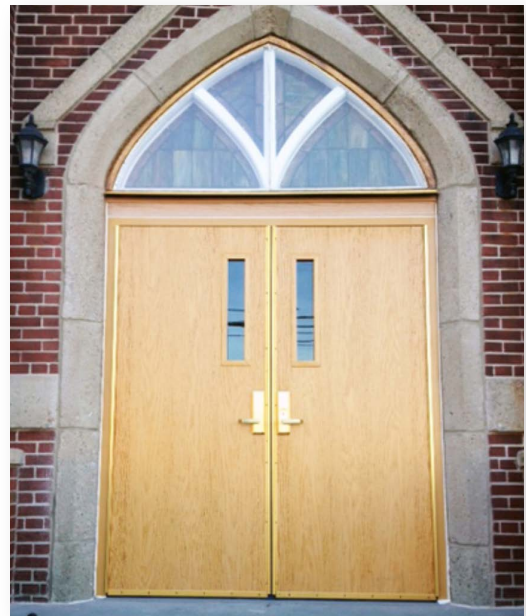

Church entry - steel doors  
with faux wood finish

## Specialty Steel Doors Quiz

1. What measurement of sound transfer is used for acoustical door assemblies?
  - a. LAOC
  - b. STC
  - c. ASTM
  - d. Both a and b
  
2. Blast doors cannot have vision panels.
  - a. True
  - b. False
  
3. Steel bullet resistant doors can be rated up to UL 752 level \_\_\_\_\_.
  - a. 4
  - b. 6
  - c. 8
  - d. 9
  
4. Which is true of hurricane doors?
  - a. They dramatically reduce the chances of personal injury or death in the event of a hurricane
  - b. They minimize property damage and create protected shelter spaces for evacuees
  - c. They allow for conformance to local or state code requirements
  - d. All of these are true
  
5. Stainless steel doors are hygienic.
  - a. True
  - b. False
  
6. Where would lead-lined doors and frames make the most sense?
  - a. In a hospital where x-rays are being taken
  - b. In a tanning salon where UV rays are excessive
  - c. At a military intelligence facility where security is a concern
  - d. Both A and C

Quiz answers are on page 32.



**Standards As Tough As Steel.**

**Steel Door Institute**

30200 Detroit Road

Westlake, Ohio 44145

440-899-0010

[info@steeldoor.org](mailto:info@steeldoor.org)

[www.steeldoor.org](http://www.steeldoor.org)

**Quiz Answers:**

**Steel Doors and Frames 101**

1=c 2=d 3=b 4=b 5=c 6=b 7=a 8=b

**Fire Rated Door Assemblies**

1=d 2=c 3=a 4=d 5=a 6=b 7=a

**Specialty Steel Doors**

1=b 2=b 3=c 4=d 5=a 6=d